

End Cable Entry/End Conduit Install

1

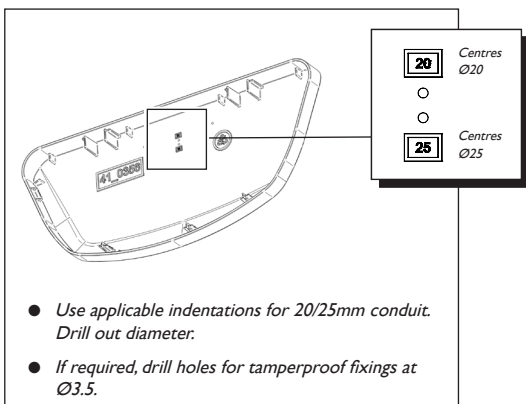

3

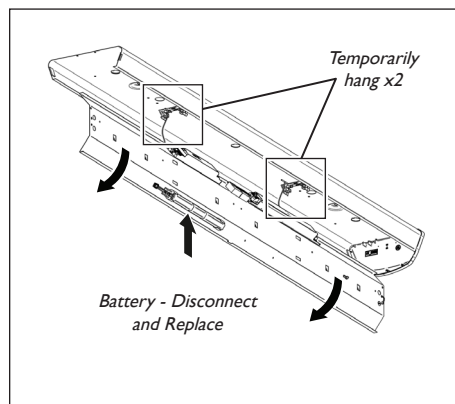

Emergency Battery Replacement

1

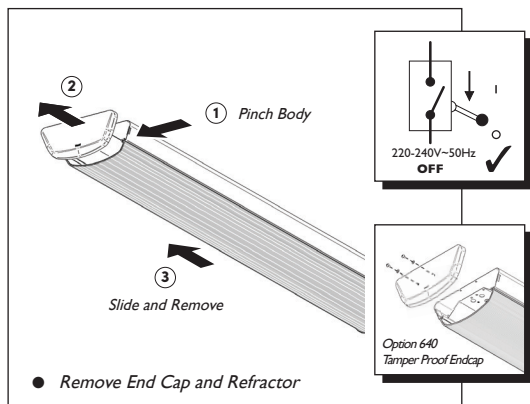

Dip Switch - Settings

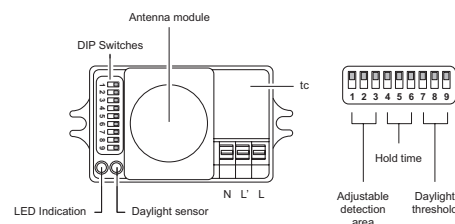

Detection area	I	2	3	Sensitivity
I	●	●	●	100% (default)
II	○	●	●	75%
III	○	●	○	50%
IV	○	○	●	30%
V	○	○	○	10%

Switch-off delay	4	5	6	Hold time
I	●	●	●	5s (default)
II	●	○	●	30s
III	●	○	○	1 min
IV	○	●	●	5 min
V	○	●	○	10 min
VI	○	○	●	20 min
VII	○	○	○	30 min

Daylight threshold value	7	8	9	Daylight Sensor
I	●	●	●	Disable (default)
II	○	●	●	50 Lux
III	○	●	○	20 Lux
IV	○	○	●	5 Lux
V	○	○	○	2 Lux

2

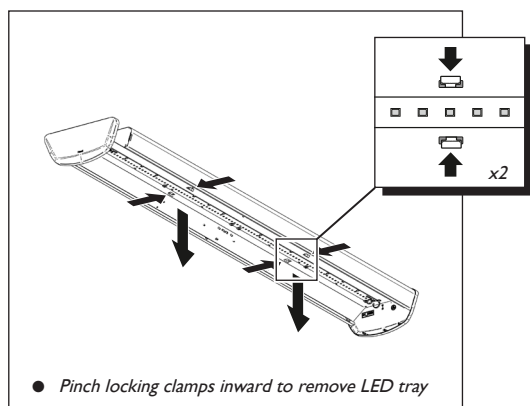

IMPORTANT INFORMATION

Tutor

SM1666 / SM1668 / SM1670 / SM1672
PN1666 / PN1668

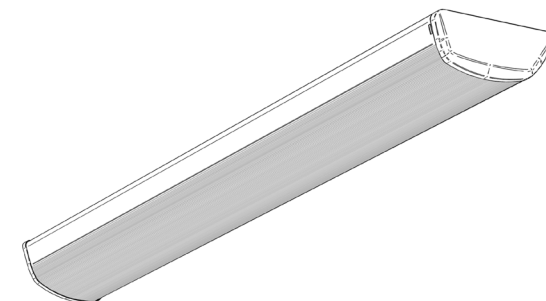

Disconnect electricity supply before installation

To be installed by qualified personnel only, in accordance with current building and wiring regulations.

When installing, we recommend wearing disposable gloves to avoid fingerprinting to the paint work of the luminaire.

Read leaflet fully before installation.

Hacel[®]
Fluent in Lighting

THE SILVERLINK, WALLSEND, NEWCASTLE UPON TYNE,
TYNE & WEAR, NE28 9ND

Technical: (0191) 280 9914
Email: technical@hacel.co.uk
Web: www.hacel.co.uk

Installation

1

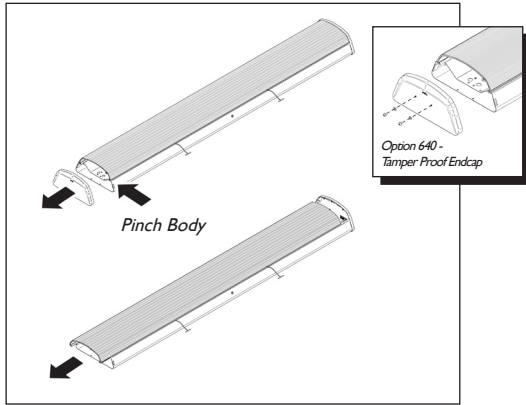

2

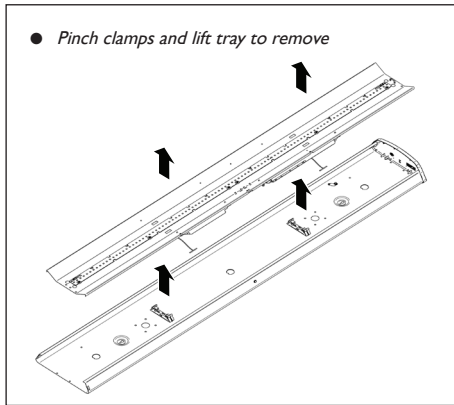

3

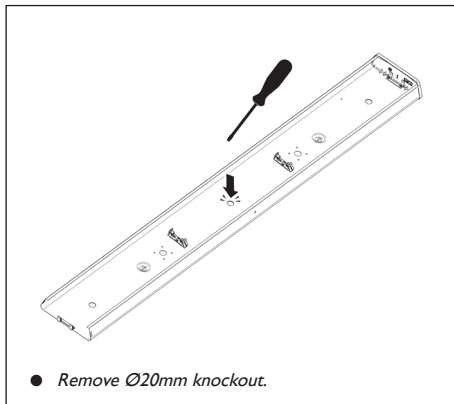

4

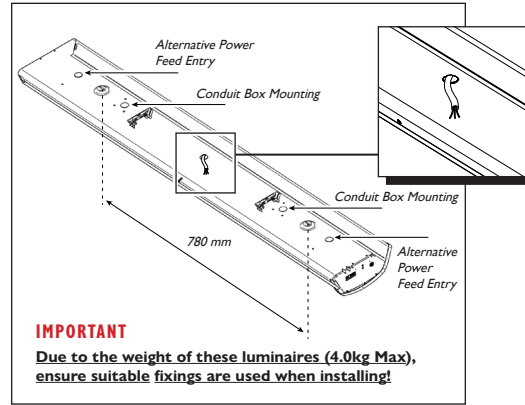

5

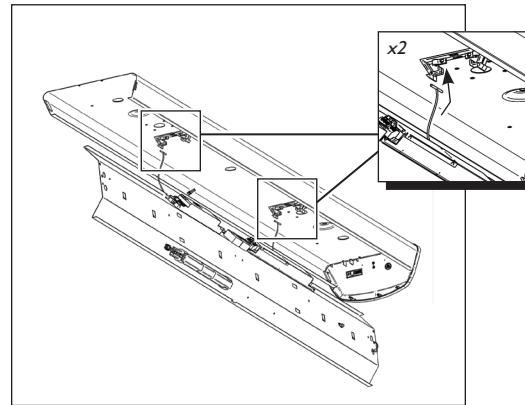

6

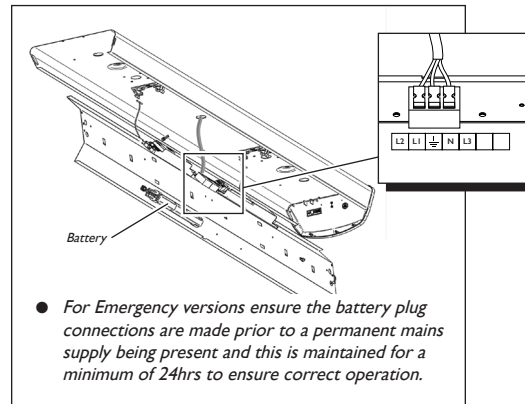

7

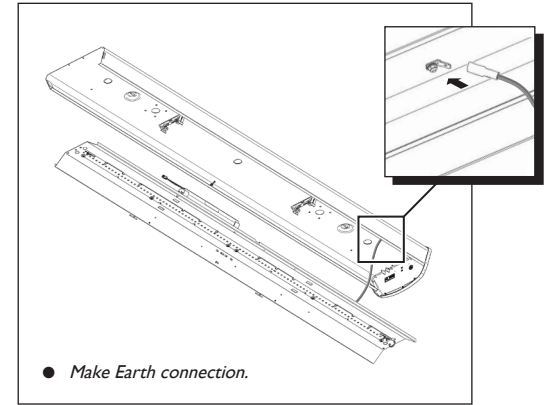

8

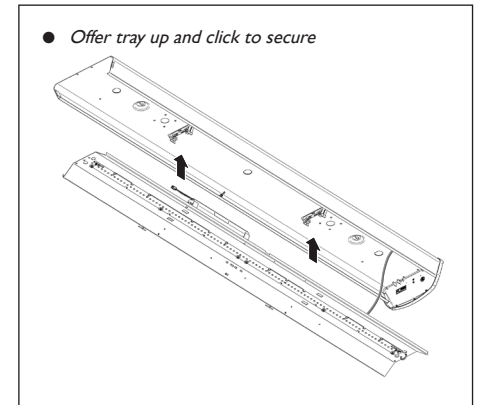

9

