

# IMPORTANT INFORMATION

## Emerge Duet IP65 WL1543

**Ensure electrical supply is isolated before fitting and/or making any electrical connections.  
Luminaires should be disconnected from the mains supply before any High Voltage Insulation tests are carried out.**

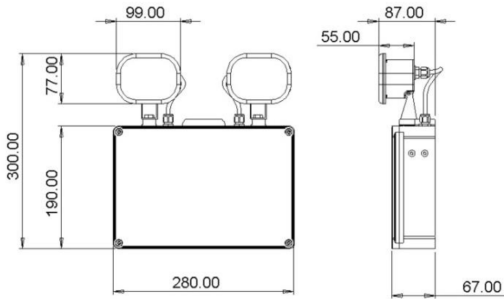

1.

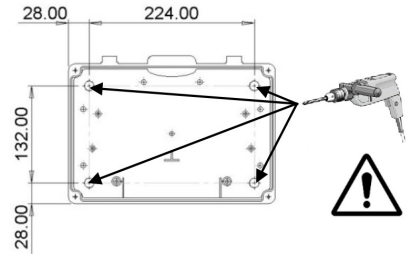

230V ac 50/60Hz  $t_a$ : 0°C...+40°C IP65

2. Remove Knockouts

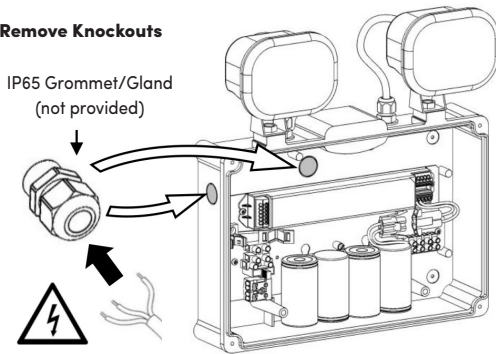

3.

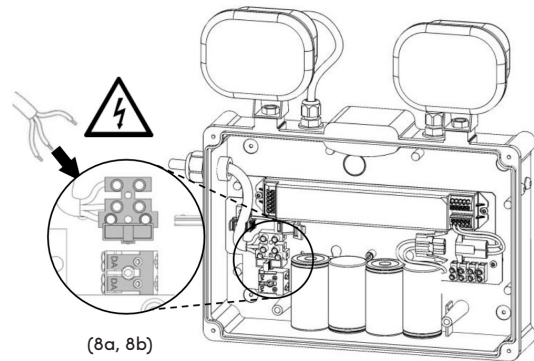

4.

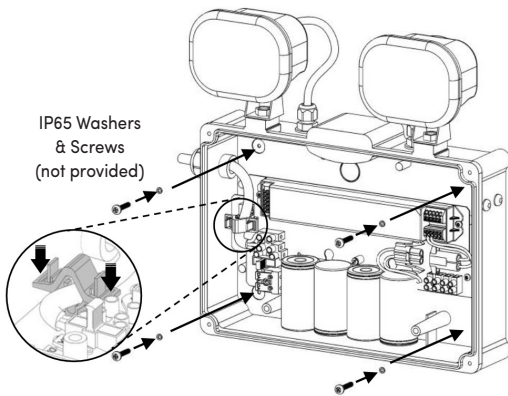

5.

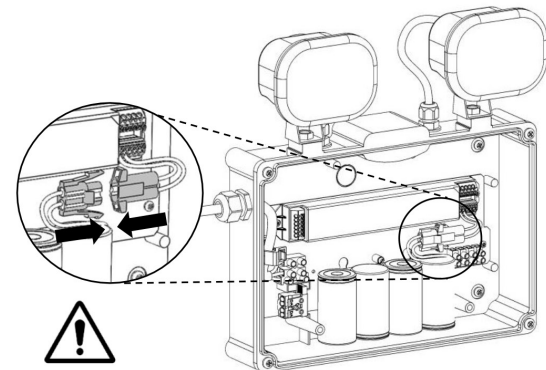

6.

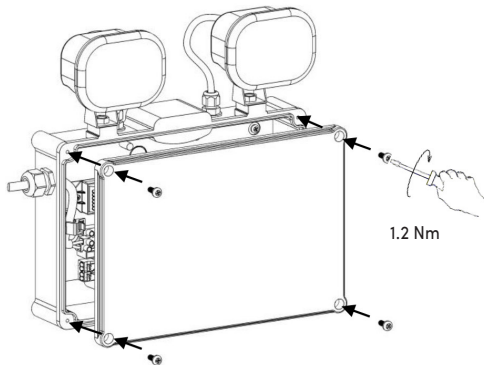

7.

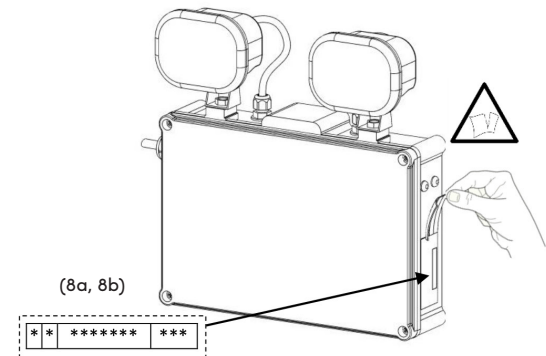

# IMPORTANT INFORMATION

8a.

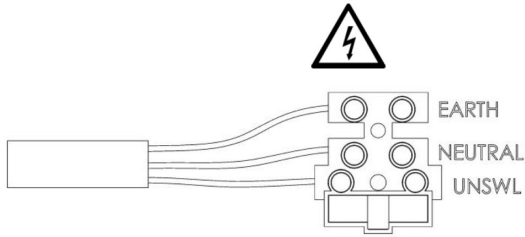

X	0	****E**	180
---	---	---------	-----

### Cable Size & Strip Length

0.75 - 1.5mm<sup>2</sup>  
Solid conductor or 7 stranded  
wire ends



8a. DALI

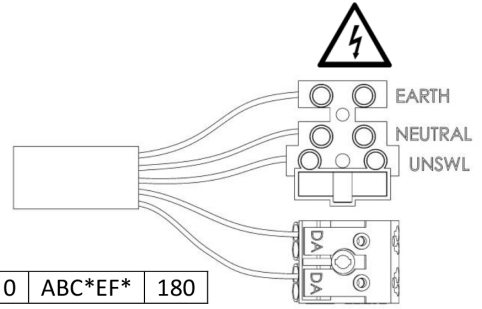

X	0	ABC*EF*	180
---	---	---------	-----

For battery replacement order codes please contact Hacer Lighting.

Lampheads should be positioned and set according to a verified lighting scheme, and should be installed out of arms reach.

The LED light source is non-replaceable. Once end-of-life is reached, the whole luminaire will need to be replaced.

### Battery Replacement

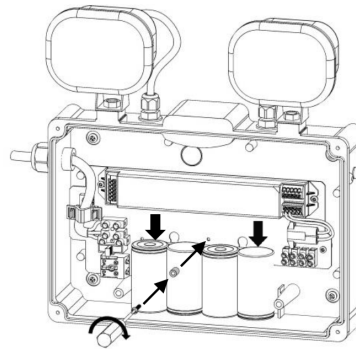
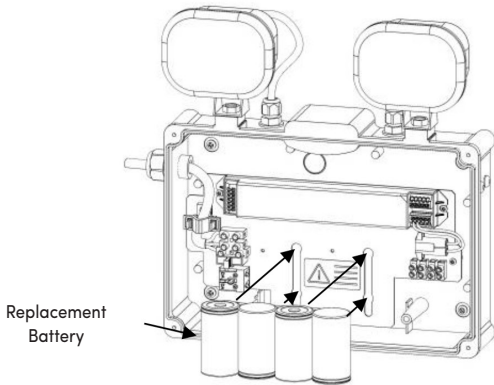
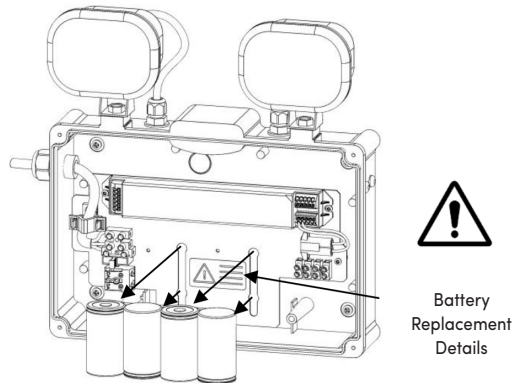
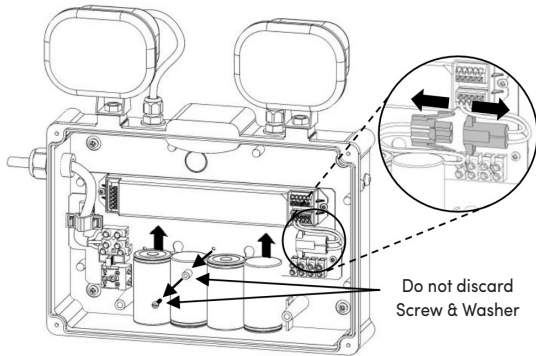

**Reconnect the electrical supply and test the installation.**