

Installation information for Remote Emergency Packs

	WHITE	- Used for dimming systems, see notes below
	RED	- Used for dimming systems, see notes below
N	BLUE	- Neutral
E	GREEN/YELLOW	- Earth
L1	BROWN	- Live
L2	BLACK	- Live (Emergency Unswitched)

For Emergency versions ensure the battery plug connections are made prior to a permanent mains supply being present and this is maintained for a minimum 24hrs to ensure correct operation.

1. Remove lid of Remote Emergency Pack.
2. Connect lamp cable to corresponding colours marked on connector blocks (if not already connected).
3. Fit cable glands (not supplied) for mains/dimming cables.
4. Connect mains/dimming cables according to information below.
5. Make battery/inverter connection before replacing lid.
6. Replace lid.

The **White** and **RED** terminals should be used as follows:

Digital Dimming (Gear types; F and G)

WHITE - DSI Signal **RED** - DSI Signal

DALI Dimming (Gear types; C, S and T)

WHITE - DALI Signal **RED** - DALI Signal

Switch Dimming (Gear types; J and K)

WHITE - Not used **RED** - Live (Dimming Switched)
BROWN - Live (Unswitched)

Dip Switch - Settings

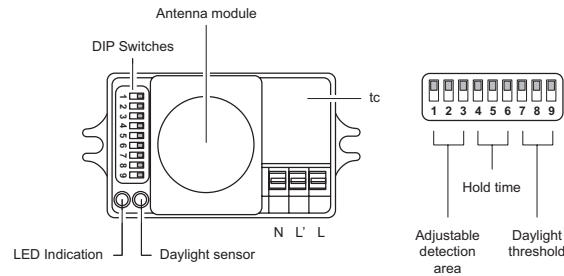

Setting up

Detection area	I	2	3	Sensitivity
I	●	●	●	100% (default)
II	○	●	●	75%
III	○	●	○	50%
IV	○	○	●	30%
V	○	○	○	10%

Switch-off delay	4	5	6	Hold time
I	●	●	●	5s (default)
II	●	○	●	30s
III	●	○	○	1 min
IV	○	●	●	5 min
V	○	●	○	10 min
VI	○	○	●	20 min
VII	○	○	○	30 min

Daylight threshold value	7	8	9	Daylight Sensor
I	●	●	●	Disable (default)
II	○	●	●	50 Lux
III	○	●	○	20 Lux
IV	○	○	●	5 Lux
V	○	○	○	2 Lux

IMPORTANT INFORMATION

Solos[®] Wall/Ceiling Light



Disconnect electricity supply before installation

To be installed by qualified personnel only, in accordance with current building and wiring regulations.

When installing, we recommend wearing disposable gloves to avoid fingerprinting to the paint work of the luminaire.

Read leaflet fully before installation.

Hacel[®]
 Fluent in Lighting

THE SILVERLINK, WALLSEND, NEWCASTLE UPON TYNE,
 TYNE & WEAR, NE28 9ND

Technical: **(0191) 280 9914**
 Email: technical@hacel.co.uk
 Web: www.hacel.co.uk

Preparation

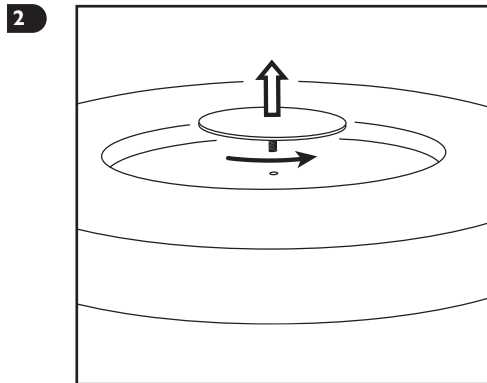
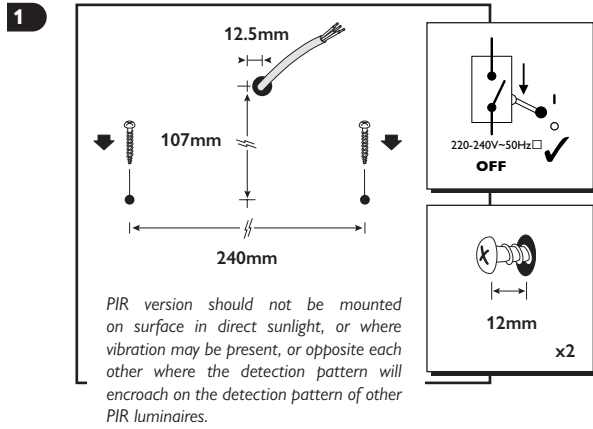

Installation

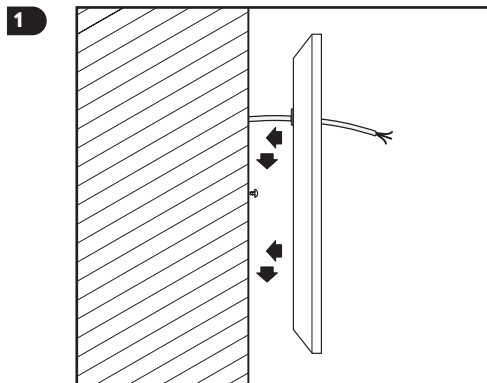

Installation Cont.

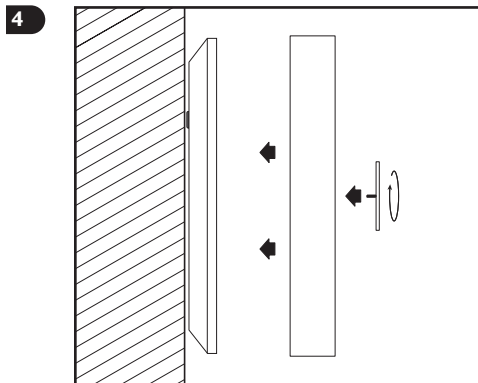
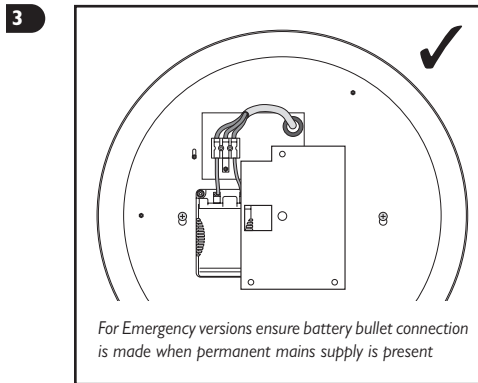
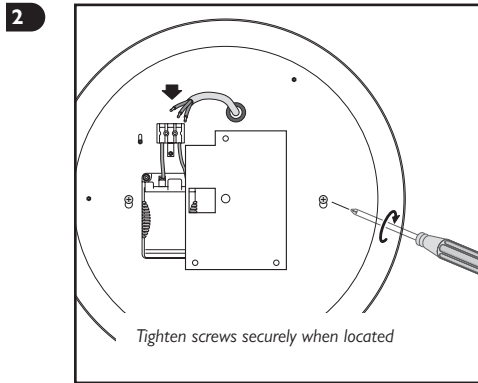

Installation Cont.

